

Red-Zone LED Pedestrian Warning Light

Forklift safety never looked brighter!

KE-RZL1

Description:

40% of all forklift accidents involve a pedestrian. Ensure pedestrians stay a safe distance away from the lift truck with the Red-Zone LED Warning Light. The Red-Zone emits a red beam on the floor to keep pedestrians away preventing foot injury or collisions from rear end swing. The Red-Zone combined with the red light offers a complete pedestrian warning system for your facility.

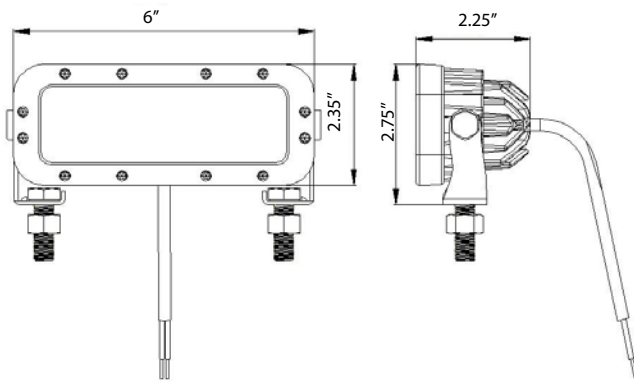

Features:

- ▶ Casting Aluminum Alloy Housing for heating elimination
- ▶ Polycarbonate lens
- ▶ High power OSRAM LED
- ▶ Waterproof, dustproof, and vibration resistant
- ▶ Double insulated wire
- ▶ Reverse polarity protected
- ▶ Voltage: 10~80V DC
- ▶ Color: Red
- ▶ Life Time: >50000 hours
- ▶ Working Temperature: -49~+185°F
- ▶ Size: 6" x 2.35" x 2.25"
- ▶ Bolt-On or Drill Free option
- ▶ IP68



Railhead Corp.
224 Shore Court, Burr Ridge, IL 60527
800-235-1782 708-844-5500
www.railheadcorp.com