

LED Forklift Approach Warning Light

1300 Lumens

KE-LTBL-2R

Description:

The KE-LTBL-2R is designed to enhance workplace safety by alerting pedestrians of forklifts approaching blind corners or forklifts entering and exiting trailers. The Blue LED light projects an intense spotlight 10 to 20 feet ahead of the forklift to alert the pedestrian of nearby traffic. The KE-LTBL-2R can be installed on the front or back of any forklift, sweeper or any other piece of industrial equipment.



Features:

Rating:	9-64V DC Multi-Voltage
Amps:	0.45 Amps @12V
Temperature:	-4 to +140 F
Lamp Type:	5W x 2 PCS (4800~5300K)
Type Approval:	CE IP67
Vibration:	10 G
Brightness:	1300 lumens
Life Span:	50,000 hours
Color:	Blue

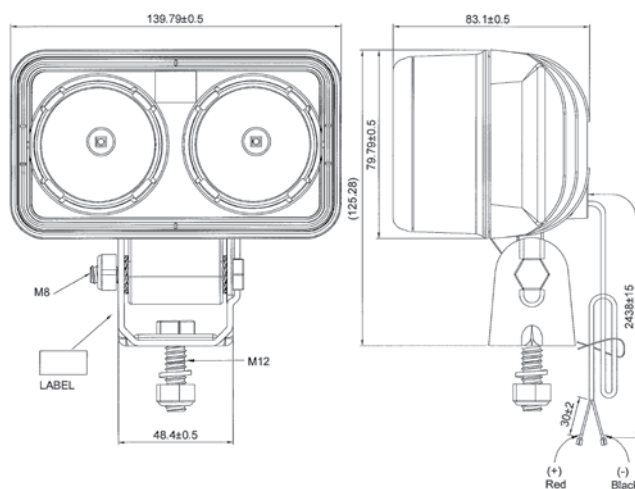

The Safe Spot has two LED lights and lenses to ensure a visible blue spot on the floor and an excellent heatsink design to ensure long LED life.

The KE-LTBL-2R meets UL approvals UL558 and UL583.



Railhead Corp.
224 Shore Court, Burr Ridge, IL 60527
800-235-1782 708-844-5500
www.railheadcorp.com